

ORION40 LIGHT

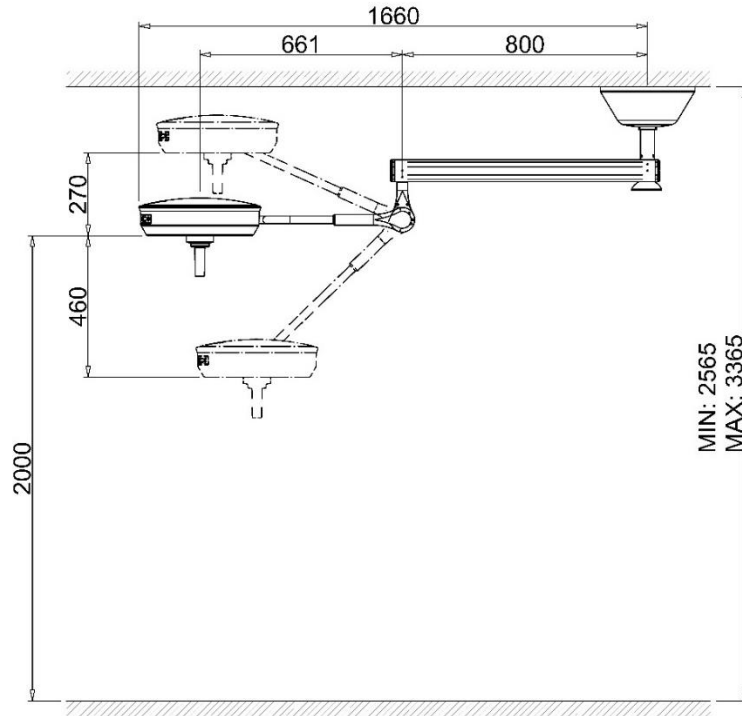

TECHNICAL PROPERTIES

Performance (at 80cm)	
ORION40 LIGHT	
Light intensity (Ec)	140klx
	60klx (<i>Dental care</i>)
Colour temperature (K)	4500/5000
Colour rendering index (CRI)	96
R9	≥ 90
Light source	n°30Led
Focus	Fissa
Light field diameter d ₁₀	24 cm
Dati elettrici	
Primary voltage (Vac)	110-230 V
Secondary voltage (Vdc)	24 V
Frequency	50/60 Hz
Power consumption	65-85 VA
Dati dimensionali	
Lamp-head diameter	40 cm
Weight	15 kg



ORION40 LIGHT ceiling ⁽¹⁾
IMPORTANT

PERFORM THE CUTTING OPERATIONS ON THE ANCHOR TUBE ACCORDING TO THE FOLLOWING TABLE

PROCEED TO INSTALL THE TUBE AND DRILL THE HOLE FOR THE APPLICATION OF THE SAFETY GRUB SCREW AS SHOWN IN THE INSTALLATION MANUAL SUPPLIED WITH THE PRODUCT

Notes

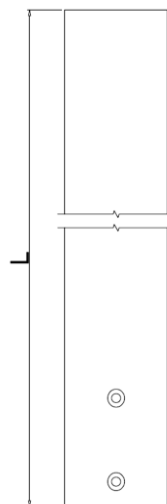
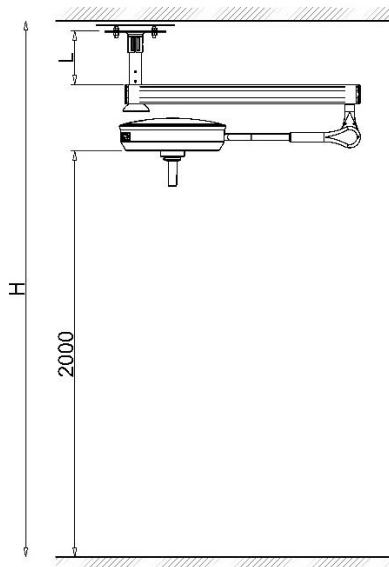
(1) in lower or higher room height conditions than indicated or in the presence of suspended ceiling, contact customer service for an evaluation on the feasibility of the project

ANCHORING TUBE LENGTH TABLES ⁽²⁾

H [mm]	L [mm]
2565	300
2665	400
2765	500
2865	600
2965	700
3065	800
3165	900
3265	1000
3365	1100

The anchor tube is supplied at the standard length of 1100mm, allowing the maximum height of 3335mm to be reached.

Notes

(2) The supplied anchor tube have a length of 1100mm. For room heights that determine a longer length of the anchor tube, it is planned to use an additional frame to lower the anchor point of the device. This frame can be at customer care or purchased as an optional accessory

CEILING COVER ⁽³⁾

The standard product foresees the supply of the ceiling cover in the high version; depending on the installation conditions, however, the ceiling cover in a flat version may be required.

- In case of false ceiling, because the electrical panel remains housed in the space between the ceiling and the false ceiling, the device is commonly equipped with flat covering.

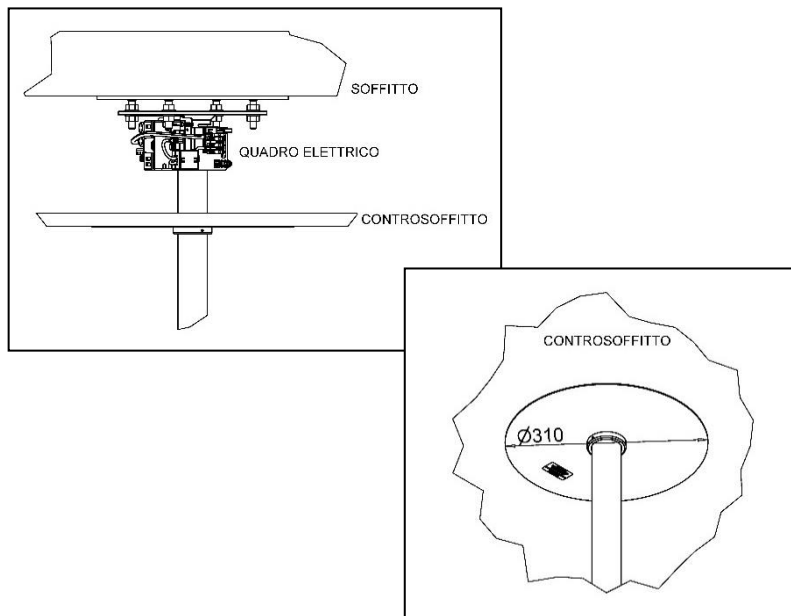

- In case of absence of false ceiling, the device is commonly equipped with high covering, required to contain the electrical panel fastened to the ceiling plate.

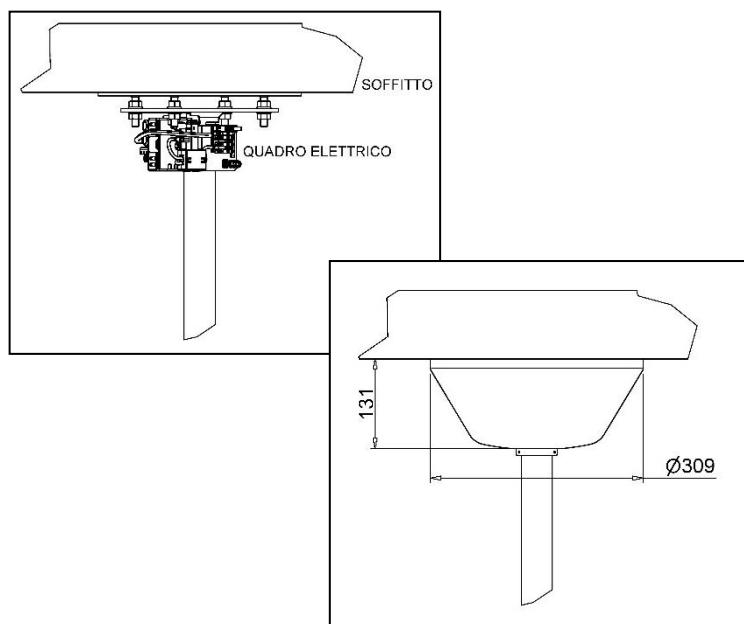

Notes
 (3) in case of requirements other than standard supply, the desired covering can be requested by expressing your choice directly on the order. The required solution will be assessed by our technical staff to determine feasibility.

CEILING ANCHORAGE CHARACTERISTICS

- PREPARING THE PREMISES MECHANICALLY

The masonry works for preparing the ceiling to install the Product must be sturdy and safe and performed in a workmanlike manner by qualified personnel under the sole responsibility of the end customer.

Qualified personnel include but are not restricted to the following professional figures: Construction Engineer, Draughtsman, Building firm, duly registered in a professional register.

The ceiling must be able to withstand a weight of at least 300 kg/m² and have a thickness of at least 250 mm. The installation premises must have building code compliance.

The process of mechanically anchoring the ceiling plate must be carried out by determining in advance the type of ceiling involved and behaving consequentially; by way of example only, below is a list of some types of walls and relative anchoring methods:

Reinforced concrete *Mechanical anchoring:* proceed to fasten the ceiling plate using n°8 screw anchors⁽⁴⁾ carefully following the instructions provided by the anchor manufacturer

Chemical anchoring: proceed to fasten the ceiling plate using n°8 injection chemical anchors⁽⁴⁾ carefully following the instructions provided by the anchor manufacturer.

Hollow-core concrete In this case, the floor slab must be sandwich closed by means of the lamp plate and counter-plate.

The plate and counter-plate shall be jointed with steel threaded bar, and clamped on the top and bottom ends with suitable washers, nuts and lock nuts.

⁽⁴⁾ the use is allowed of anchoring means/threaded bars of size up to M10 at most, due to the diameter of the through holes of the plate.

- DRILLING SCHEME⁽⁵⁾

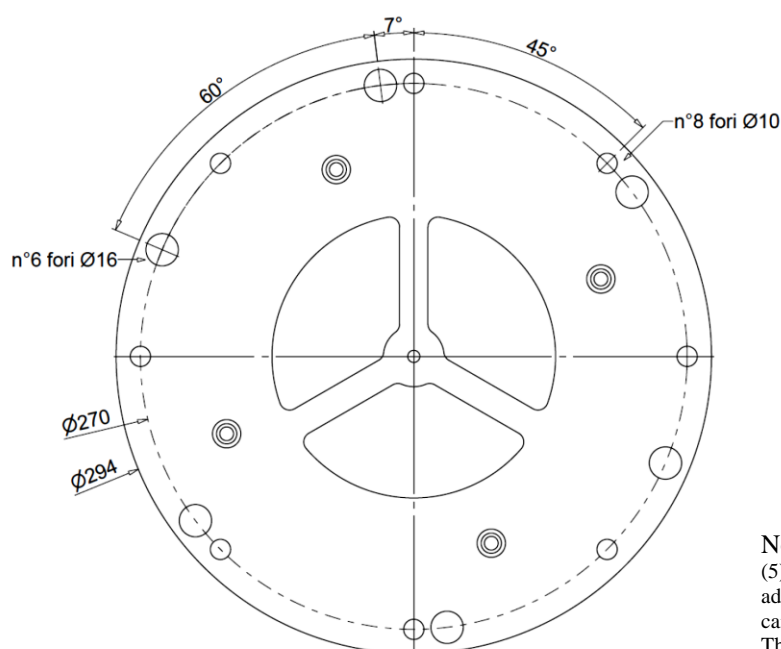

Ceiling plate

Notes

(5) Optionally, it is possible to request the supply of an additional plate and counter-plate system, to which the device can then be fixed by means of the TIGES plate shown alongside. The drilling pattern of the additional system differs from that shown alongside.

For further information or to request the plate and counter-plate system, please contact customer service.

	ORION40 LIGHT lamp CEILING version	EN	06 June 2022
		Rev.0	Page 5 / 7

STATIC AND EXECUTION CONFORMITY

Preliminary conditions for static conformity

Competent building technicians must confirm in writing compliance with the national directives and the following points.

The customer must keep the certification together with the product documentation and attach a copy to the order.

1. The installation premises must have building code compliance.
2. Competent building technicians must establish in advance the anchoring method best suited to the type of ceiling and accept responsibility for their decision.
3. The supporting ceiling must be able to withstand a weight of at least 300 kg/m² and have a thickness of at least 250mm.
Any other loads must also be taken into consideration acting above the ceiling as well as loads anchored to the ceiling itself.
The load-bearing ceiling should be preferably made of reinforced concrete.
4. Each of the eight ceiling anchoring devices should have a load-bearing capacity of at least 2000N (≈200kg).

Such load-bearing capacity can be determined according to the following points:

- Indications provided by the anchoring device manufacturer
- Quality of the load-bearing ceiling, e.g., the strength of the reinforced concrete
- Arrangement of the anchors, with reduction due to distance between them

- CORRECTLY WIRING UP THE PREMISES

The premises used for medical purposes must be safely wired up in a workmanlike manner by qualified personnel.

Qualified personnel include but are not restricted to the following professional figures:

Electrical Engineer Electro-technical expert qualified to work as an electrician.

The wiring system of the environment (premises) in which installation is made must be in conformity with CEI 64-8 standards (IT regulations for premises used for medical purposes) and with applicable national laws and/or regulations.

The electrical system must be certified by an electrician qualified to issue the certificate of conformity.

The earth system must be certified as required by applicable regulations.

The electrical system must envisage laying cables suitable to the electrical characteristics of the Product to be supplied.

The electrical system must feature a protection fuse or thermal magnetic disconnection switch upstream of the Product, to avoid the risk of its being damaged following faults and/or malfunctions of the power mains.

CONFORMITY DECLARATION

On the basis of the above points, we certify that the static calculation, mechanical works for preparing the anchorage of the product and the preparation of the electrical system have been carried out safely, according to the rule of art.

IMPORTANT:

TECNO-GAZ S.p.a. disclaims all liability for any type of fault or damage which might occur over time due to the electrical system installed in the premises not being suitable

PRODUCT OPERATING AREA

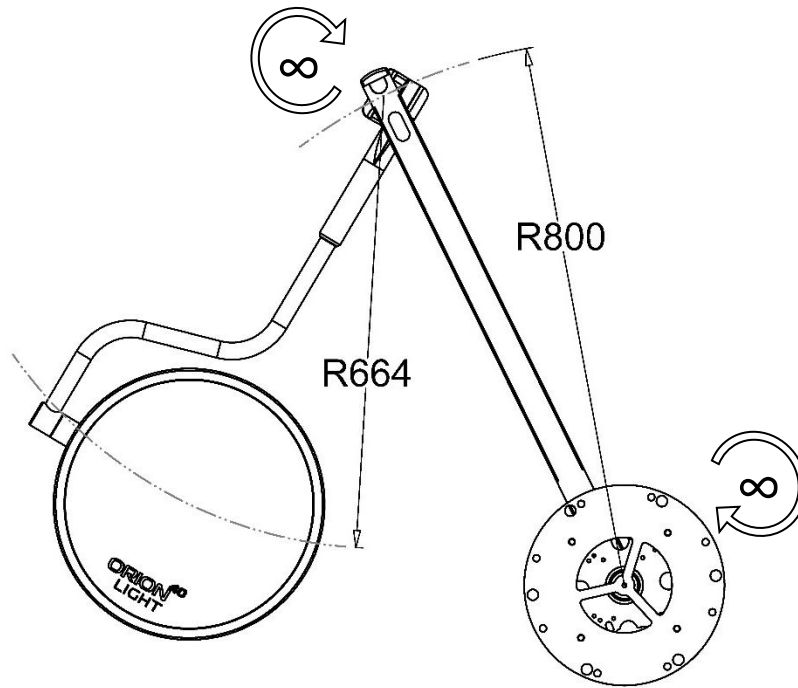

WORK DISTANCE

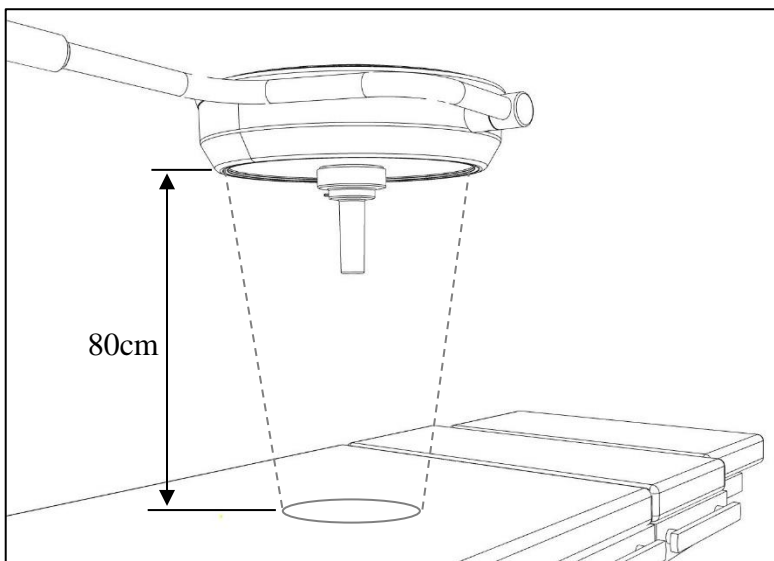

To have the optimization of light intensity, we recommend using the product at a distance of 80cm.

However, the product provides good light intensity even when used at a distance of 70cm to 140cm

LAMP FASTENING POINT

To ensure best device operation, it is best to secure the product as shown in the pictures below:

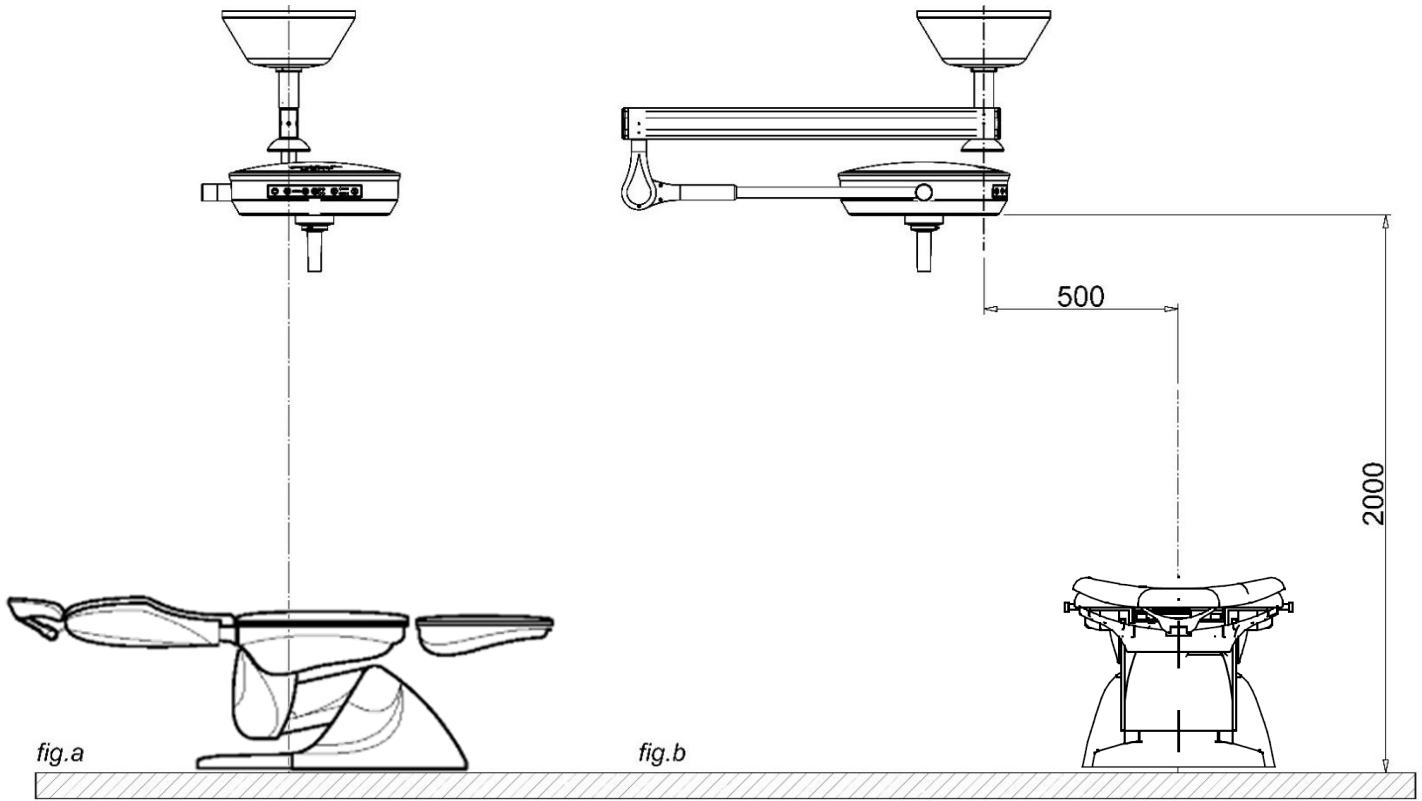

Fasten the plate to the ceiling so the anchoring tube is aligned along the same plane as the surgery lamp fitting seat (*Fig. a*) and about 500mm from the longitudinal axis of the surgery chair (*Fig. b*), ⁽⁶⁾.

(6) If there are obstacles that prevent the device from being fixed in the recommended position (such as ceiling lamps), this positioning must be carried out at the sole discretion of the end user, considering possible on-site solutions which prevent the lamp from interfering with the other devices present.

LAMP POSITIONING

Use the device by positioning it so that the horizontal arm of the device is on the left side of the patient, while the oscillating arm faces the patient so that the dome falls below the anchor tube. In this way, the vertical movement of the arm and the two rotations of the yoke (α) and cupola (β) can be used to illuminate the desired area.

